

Quieter. Faster. And Fully Automatic.

It's all new and fully automatic. Say good-bye to your air compressor, the completely redesigned Apex Pro X2 is packed with our most advanced hydraulic system. It uses dual heated platens to decrease your cook time without affecting the dough rise.



Apex Pro X2

Hydraulic Automatic Dough Press
DP2350

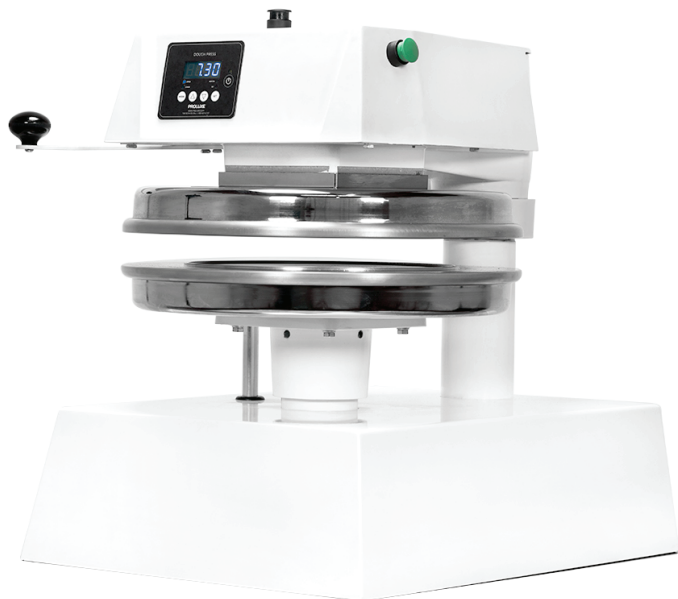

Consistent Pizza

Thanks to the embedded mold, you'll have a perfect crust every time.



250-300 PIZZAS PER HOUR



DUAL HEATED PLATENS LIFETIME LIMITED WARRANTY



NO COMPRESSOR REQUIRED



HIGH PRODUCTION

Apex Pro X2

DP2350

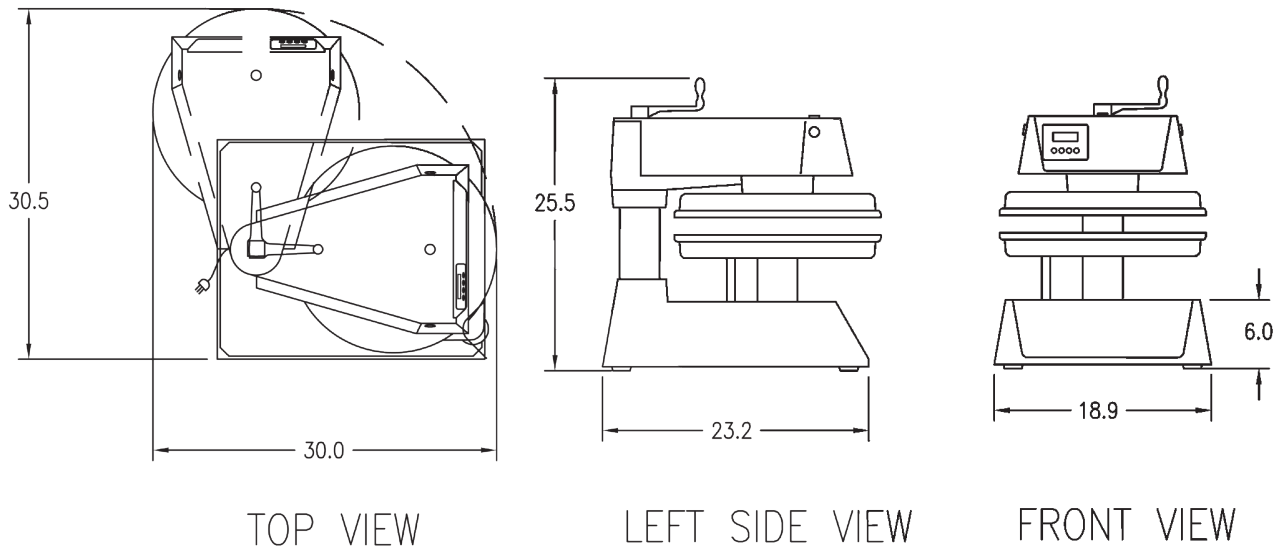

Equipment Details

Temperature Control	Yes	Pies Per Hour	300+
Maximum Heat	450F/232C	Shipping Weight	225lbs/102kg
Programmable Timer	Yes	Machine Weight	202lbs/91kg
Thickness Control	Yes	Voltage	208/220
Power Cord Length	72"	Wattage	4600/5146
Power Plug	NEMA 6-30P	Amps	22.1/20.9

