

## The New Generation of Hand-tossed Pizza

The Endurance X1 manual dough press is designed for product versatility, mid-volume kitchens, and consistency. The single upper heated platen helps your dough relax, press, and hold its shape. Thanks to the thickness control dial you can press hand-tossed style pizza to fortune cookie dough, all with consistency.

### Endurance X1

Manual Dough Press  
DP1100



## Toss Out Skilled Labor

Designed with a flat platen for freedom to press a range of sizes on one single press.



150-250 PIZZAS PER HOUR



HEATED UPPER PLATEN LIFETIME LIMITED WARRANTY



FLAT 18" BOTTOM PLATEN



PRESSED IN SECONDS

# Endurance X1

DP1100

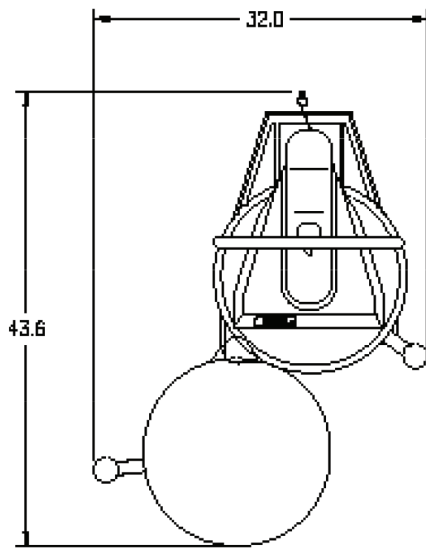

TOP VIEW

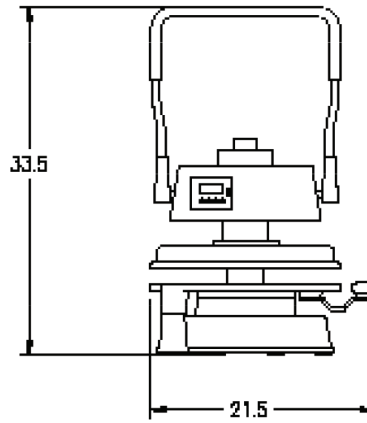

FRONT VIEW

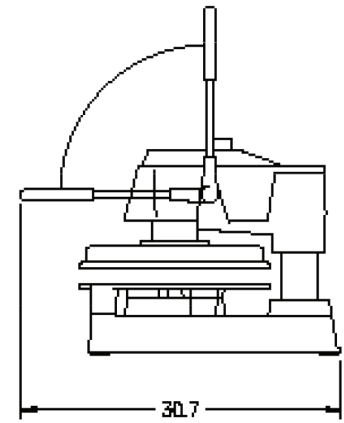

RIGHT SIDE VIEW

## Equipment Details

Temperature Control	Yes	Pies Per Hour	200+
Maximum Heat	450F/232C	Shipping Weight	175lbs/79kg
Programmable Timer	Yes	Machine Weight	140lbs/63kg
Thickness Control	Yes	Voltage	120/220/240
Power Cord Length	72"	Wattage	1500
Plug	NEMA 5-20P/6-15P CEE7/7	Amps	12.5/6.3/6.8

